



Warnings and cautions

- > Low pressure gauges can very easily be over pressured if not careful. Please take caution when applying pressures.
- > Do NOT exceed the safety pressure limit (3500 psi / 235 Bar).
- > Do not switch between pressure and vacuum mode under pressure. Make sure you have vented the pressure and opened the isolation valve before switching to vacuum.
- > Over tightening connectors may cause damage.
- > Pump should be stored in a dry/clean environment.
- > Do NOT hold pressure above 1000 psi for more than 4 hours.
- > All moisture and contaminants should be cleaned out of the liquid isolator before creating a vacuum. This is accomplished by venting the pump when at high pressure.
- > For the least risk in contamination of the reference gauge, the DUT should be installed to the pressure port which is closest to the vent valve.
- > Additel is not liable for any safety problems or damages caused by misuse or incorrect operation.

Specification

- > **Pressure range:** 95% vacuum to 3000 psi (200 bar)
(Based on an atmospheric pressure of 1 bar)
- > **Temperature:** 0 to 50 °C / 32 to 122 F
- > **Humidity:** < 85%RH
- > **Adjustment resolution:** 0.001psi (0.1mbar, 10 Pa)
- > **Overpressure Safety Limit:** 3500 psi (235 bar)
- > **Pressure media:** Air
- > **Weight:** 14.4 lbs (6.5 kg) for 920, 20 lbs (9.07 kg) for 920HV
- > **Piston volume:** 60 ml (3.7 in³) for 920, 115 ml (7.02 in³) for 920 HV

*Remark: If local atmosphere pressure is 1 bar, the vacuum can reach to -0.95 bar;
If local atmosphere pressure is P, the vacuum can reach to - 0.95P bar.*

ADT920, 920HV

Pneumatic High Pressure Test Pump User's Manual

[Version number:1905V05]

Please download the latest version from www.additel.com



Air routine

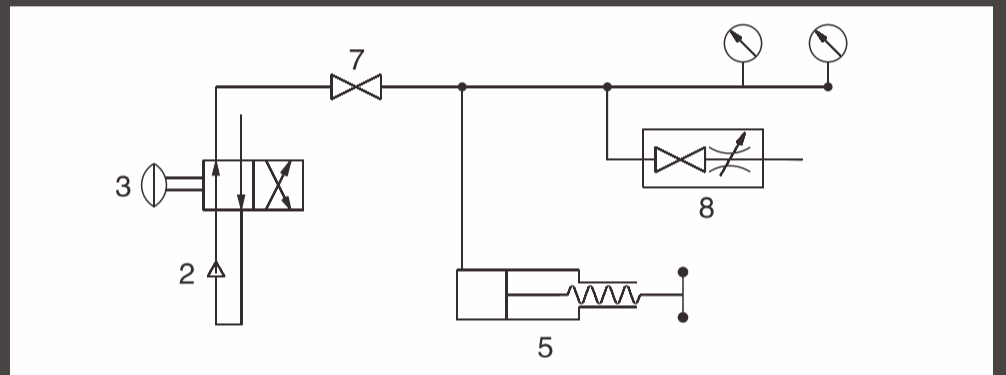

Configuration & Size

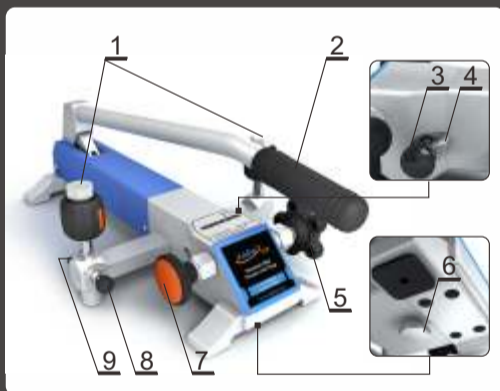

- 1 – Quick connector
- 2 – Hand pump
- 3 – Pressure/vacuum (P/V) selector
(Positive pressure: pull it out; Vacuum: push it in)
Do NOT switch while unit is under any pressure
- 4 – Pressure/Vacuum lock
- 5 – Fine adjust handle
(Turn Clockwise to increase pressure)
- 6 – Maintenance cleaning port
- 7 – Isolation valve
(isolates the calibration volume from the hand pump and check valve)
- 8 – Vent valve
(clockwise to close/counter clockwise to release pressure)
- 9 – Vent port

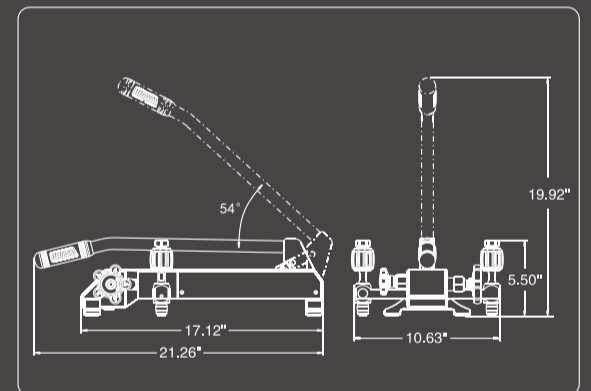

Troubleshooting

Problem	Cause	Solution
Hand pump will not generate pressure	The isolation valve is not open.	Open the isolation valve.
It is difficult to increase pressure	A. Vent valve is not closed.	Close the vent valve.
	B. The O-ring seal is loose or damaged	Replace O-ring seal.
	C. P/V selector is in the wrong position.	Pressure : Pull P/V selector out; Vacuum : Push the P/V selector in.
	D. Internal tubing is dirty.	Disassemble and clean (Request diagram).
Hard to use fine adjust	A. The isolation valve is not closed.	Close the isolation valve.
	B. The gauges are not tightened.	Tighten the reference gauge and / or the gauge under test.
	C. The O-ring seal is aged or frayed.	Replace O-ring seal.
	D. The connector type is mismatched to the gauge pressure port.	Use the correct adaptor.
	E. Air route is blocked/dirty.	Pressurize to high pressure and release pressure quickly via the vent valve.
Not easy to turn fittings	A. Too much force was previously applied.	Do not over tighten. Hand tight is sufficient.
	B. The threads have no lubrication.	Lubricate the thread.
	C. The connector type is mismatched to the gauge pressure port.	Use the correct adaptor.

O-Rings for pressure connector

P/N	Size	Connector
1611300004	4X1.5	M10X1, 1/8BSP, 1/8NPT
1611300220	6.5X3	M20X1.5, 1/2BSP, 1/2NPT
1611300024	6X2	M14X1.5, 1/4BSP, 1/4NPT, 3/8BSP

Connection

A

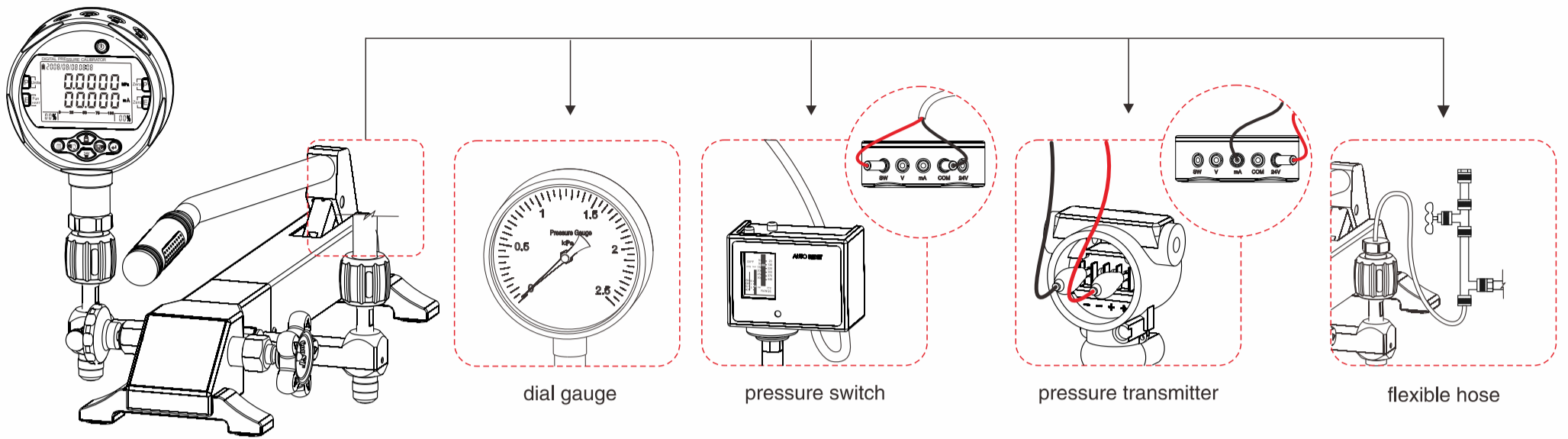

Vent

B

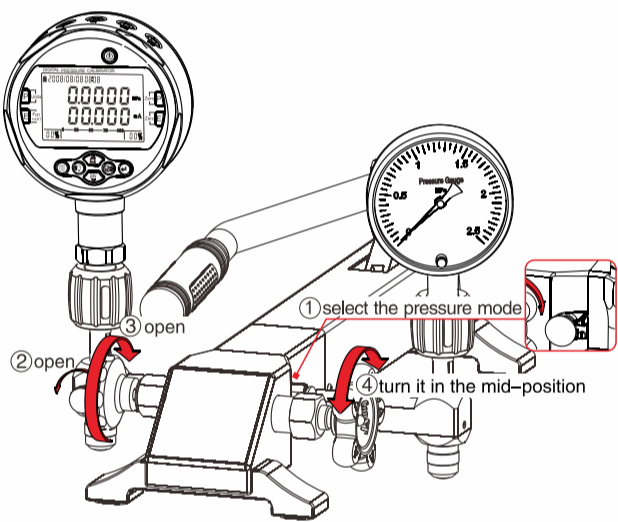

Zeroing should be operated under this condition only.

Increase pressure process

C

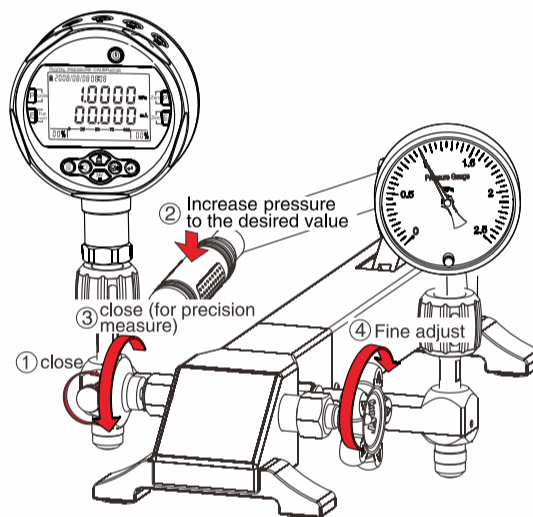

Decrease pressure process

D

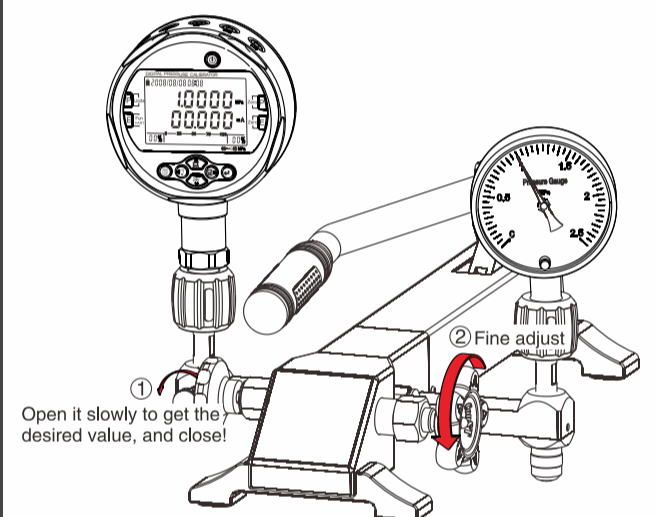

Preparation for vacuum

E

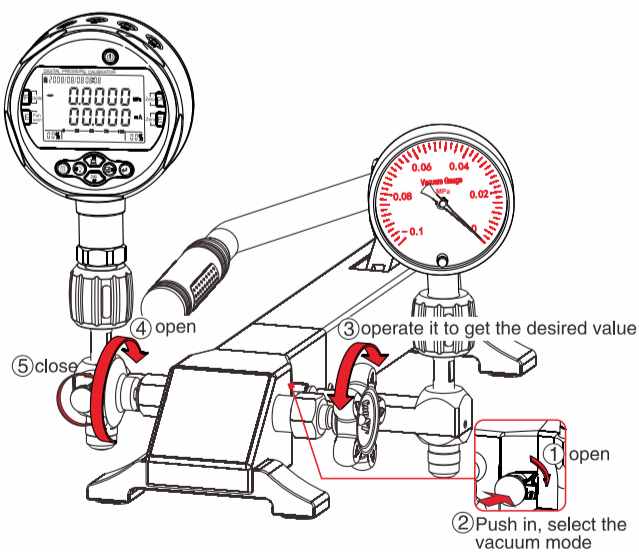

⚠ Open to atmosphere before operation

Vacuum process

F

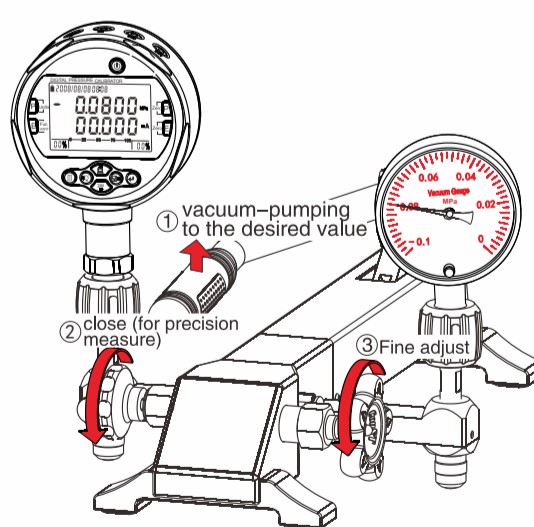

Decrease vacuum process

G

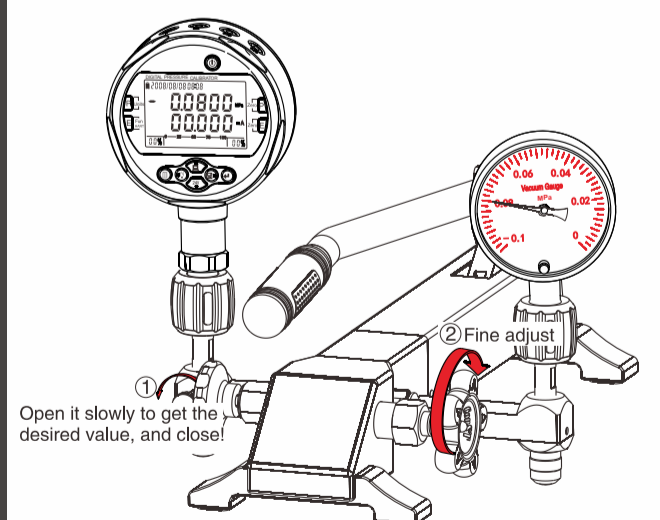

Remark: A: Additel has made a concerted effort to provide complete and current information for the proper use of the equipment. The product specifications and other information contained this manual are subject to change without notice.

B: Above pictures are just for reference.